

CANDIDATE
NAME

--

CENTRE
NUMBER

--	--	--	--	--

CANDIDATE
NUMBER

--	--	--	--



COMBINED SCIENCE

5129/21

Paper 2

October/November 2016

2 hours 15 minutes

Candidates answer on the Question Paper.

No Additional Materials are required.

READ THESE INSTRUCTIONS FIRST

Write your Centre number, candidate number and name on all the work you hand in.

Write in dark blue or black pen.

You may use an HB pencil for any diagrams, graphs or rough working.

Do not use staples, paper clips, glue or correction fluid.

DO NOT WRITE IN ANY BARCODES.

Answer **all** questions.

A copy of the Periodic Table is printed on page 24.

Electronic calculators may be used.

You may lose marks if you do not show your working or if you do not use appropriate units.

At the end of the examination, fasten all your work securely together.

The number of marks is given in brackets [] at the end of each question or part question.

This document consists of **23** printed pages and **1** blank page.

1 A toy helicopter of mass 0.043 kg is shown in Fig. 1.1.

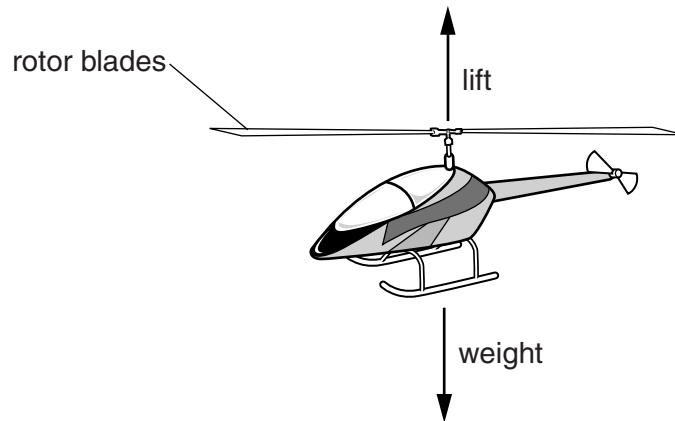

Fig. 1.1

The helicopter hovers in a stationary position above the ground.

The weight of the helicopter is opposed by the lift produced by the rotor blades.

(a) The gravitational field strength g is 10 N/kg.

(i) Calculate the weight of the helicopter.

weight = N [1]

(ii) The helicopter moves through a vertical distance of 0.50 m.

Calculate the useful work done in moving the helicopter to this new height.

work done = J [1]

(b) In order to raise the helicopter through a vertical distance of 0.50 m, the motor in the helicopter supplies more energy than the useful work done in moving the helicopter.

Suggest what happens to this extra energy.

.....
 [1]

2 A section through a leaf is shown in Fig. 2.1.

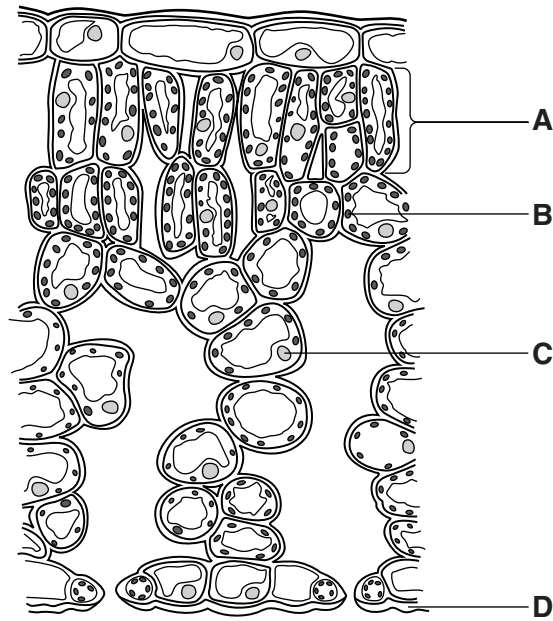

Fig. 2.1

(a) (i) Name the structures **A**, **B**, **C** and **D**.

- A**
- B**
- C**
- D**

[4]

(ii) State the function of structure **D**.

.....
 [1]

(b) The stomata of a leaf allow gases to pass in and out of a leaf.

In a leaf, the processes of photosynthesis, respiration and transpiration take place.

Use the names of gases to complete Table 2.1 to show the **net** movement of the different gases into and out of a leaf in dark conditions and in light conditions.

Table 2.1

net movement of gases in dark conditions		net movement of gases in bright light conditions	
gases into leaf	gases out of leaf	gases into leaf	gases out of leaf

[5]

(c) State the functions of xylem and of phloem.

xylem

.....

.....

phloem

.....

.....

[3]

- 3** Sulfur dioxide reacts with oxygen to produce sulfur trioxide.

The equation for the reaction is shown.

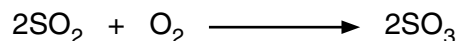

The relative molecular mass of sulfur dioxide is 64.

- (a) (i)** Calculate the relative molecular mass of sulfur trioxide.

[A_r: O, 16; S, 32]

..... [1]

- (ii)** Complete the following sentences.

128 g of sulfur dioxide react withg of oxygen and produceg of sulfur trioxide.

3.2 g of sulfur dioxide produceg of sulfur trioxide.

[3]

- (b)** Sulfur trioxide reacts with water to produce sulfuric acid.

Construct an equation for this reaction.

..... [1]

- (c)** Name one substance that reacts with sulfuric acid to produce copper(II) sulfate.

..... [1]

- (d)** Sulfur dioxide is an atmospheric pollutant.

Explain why the combustion of fossil fuels leads to the formation of sulfur dioxide.

.....

..... [1]

4 A vernier caliper is used to measure the diameter of a ball.

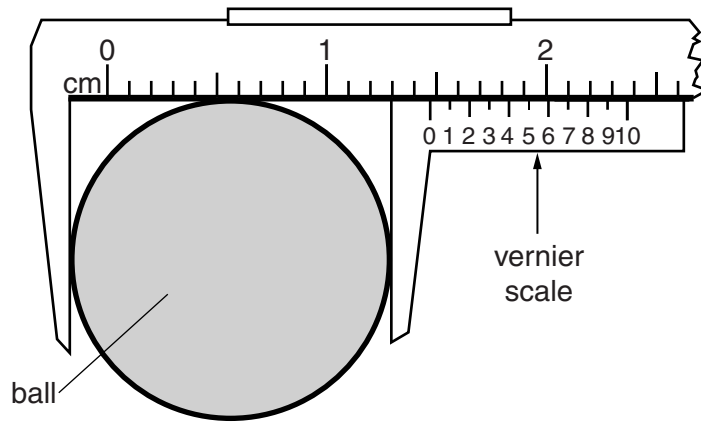

Fig. 4.1

(a) State the reading shown on the vernier scale in Fig. 4.1.

reading = cm [1]

(b) The ball moves down a slope and passes through points X and Y, as shown in Fig. 4.2.

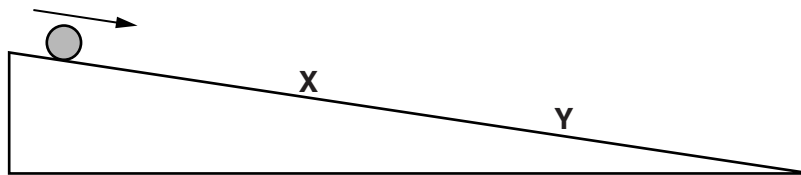

Fig. 4.2

Describe how the time taken for the ball to move from X to Y is measured.

.....

 [2]

5 (a) Name **two** substances that are produced by the liver.

1.

2.

[2]

(b) Name **two** substances that are broken down in the liver.

1.

2.

[2]

6 The following is a list of gases.

argon ammonia carbon dioxide carbon monoxide
helium hydrogen nitrogen oxygen

Use the list to complete the following sentences.

Each gas may be used once, more than once or not at all.

(a) is produced by the incomplete combustion of methane. [1]

(b) is the most abundant gas in the air. [1]

(c) reacts with water to produce a solution with pH 9. [1]

(d) is **not** present in polluted air. [1]

(e) provides an inert atmosphere in lamps. [1]

7 The solar panel shown in Fig. 7.1 is fixed to the roof of a house.

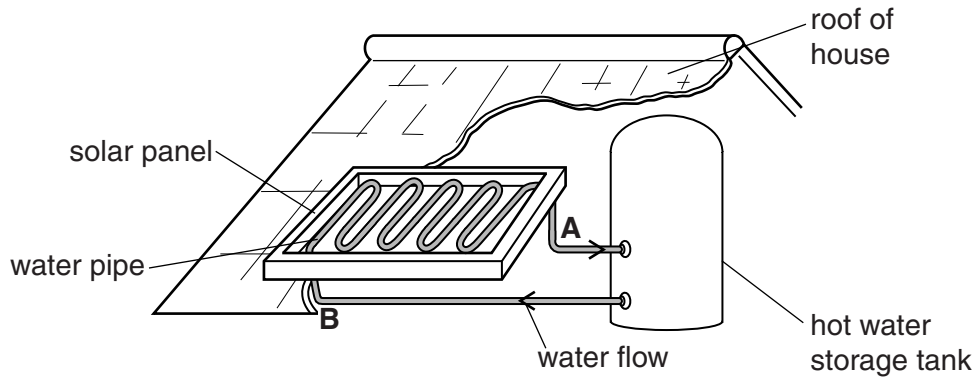

Fig. 7.1

A long pipe is looped many times through the panel.

Water is pumped through this pipe.

(a) Solar energy is incident on the panel.

State how the water flowing **away** from the panel at **A** is different from the water **returning** to the panel at **B**.

..... [1]

(b) The water pipe in the panel is made from copper.

(i) Explain why the pipe is made from copper.

.....
 [1]

(ii) Explain why the panel and the pipe are coloured black.

.....
 [1]

(c) The pipe carrying hot water from the panel enters the storage tank towards the middle.

Explain why the pipe enters the tank towards the middle rather than at the top.

.....
.....
..... [2]

8 Light rays **C** and **D** are incident on a converging lens, as shown in Fig. 8.1.

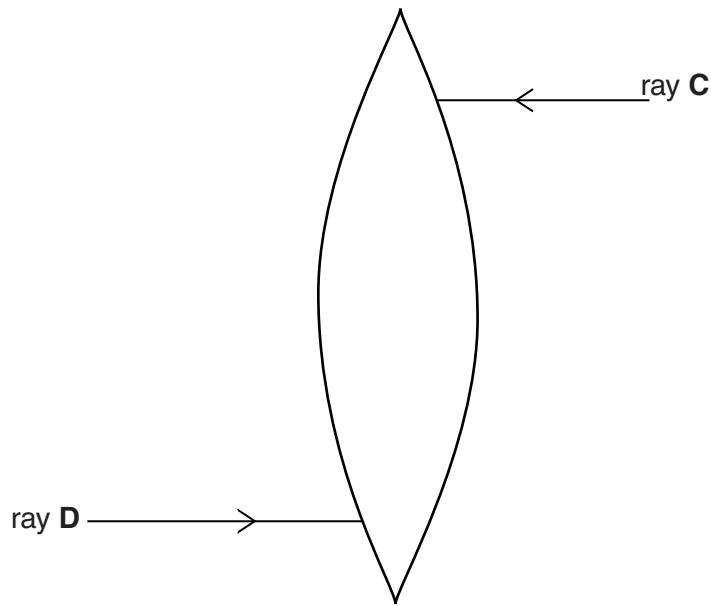

Fig. 8.1

On Fig. 8.1, use a ruler to draw lines to show the paths of rays **C** and **D** through the lens. Continue the lines to show how both rays emerge from the lens. [2]

9 The daily energy requirements of different people are shown in Fig. 9.1.

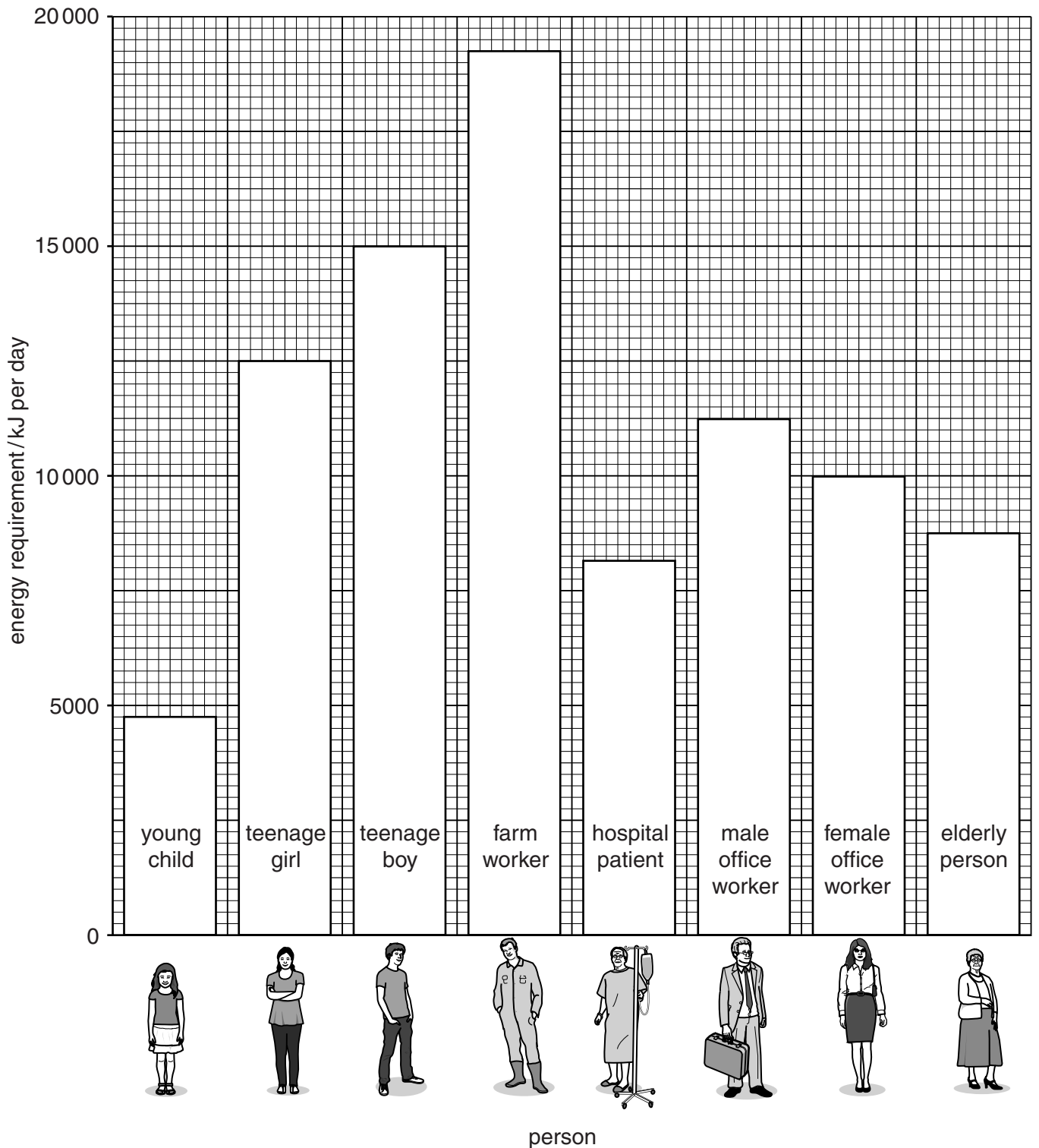

Fig. 9.1

(a) (i) State the occupation of the person who has the highest daily energy requirement.

..... [1]

(ii) State the energy requirement of the female office worker.

.....kJ per day [1]

(b) A male office worker has an intake of 15000 kJ per day.

Use information in Fig. 9.1 to explain why he is likely to become overweight.

.....
.....
.....
..... [2]

(c) Use information in Fig. 9.1 to suggest **two** factors that affect the daily energy requirement of a person.

1.
.....
2.
..... [2]

10 Table 10.1 shows the structure of the atoms of some elements, **R** to **V**.

The letters are not the chemical symbols of the elements.

Table 10.1

element	nucleon number	proton number	number of neutrons	electronic structure
R	15	7		
S	20	10	10	2,8
T	24	12	12	2,8,2
U	37		20	2,8,7
V		18	22	2,8,8

(a) Complete Table 10.1. [4]

(b) State which two elements are in the same group of the Periodic Table.

..... and [1]

(c) (i) Deduce the formula of the compound formed by elements **T** and **U**.

..... [1]

(ii) State the type of bonding in this compound.

..... [1]

11 A part of the electromagnetic spectrum is shown in Fig. 11.1. The names of two regions are shown.

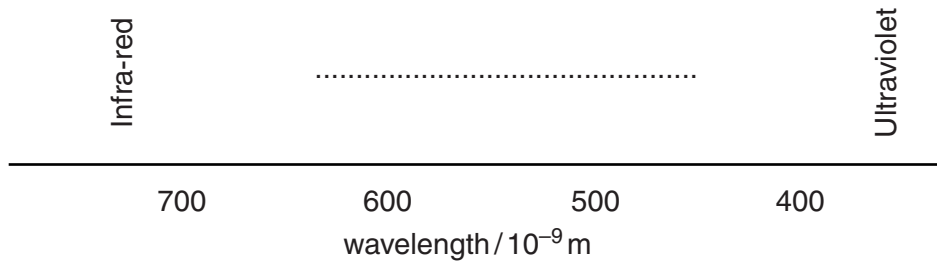

Fig. 11.1

- (a) (i) Name the region of the electromagnetic spectrum between infra-red and ultraviolet.
 [1]
- (ii) State the speed of the electromagnetic waves in a vacuum.
 [1]
- (b) Name the property of a wave that **increases** from infra-red to ultraviolet.
 [1]
- (c) An electromagnetic wave is described as a transverse wave.
 Name a wave, other than an electromagnetic wave, that is transverse.
 [1]

12 Choose words or phrases from the list to complete the sentences.

Each word or phrase may be used once, more than once or not at all.

- glands kidney lung plasma**
red blood cells target

Hormones are chemicals produced by

Hormones are carried round the body in

A hormone alters the activity within a organ.

[3]

13 Methane is the main constituent of natural gas and is a fuel.

The combustion of methane is exothermic.

(a) (i) Explain the meaning of the word *exothermic*.

.....
 [1]

(ii) State the names of the products when methane burns in excess oxygen.

..... and [2]

(b) Methane is the simplest member of the homologous series called the alkanes.

Describe the general characteristics of a homologous series.

.....

 [2]

(c) Draw the structure of methane.

[1]

14 A stiff wire is moved vertically between the poles of a magnet, as shown in Fig. 14.1.

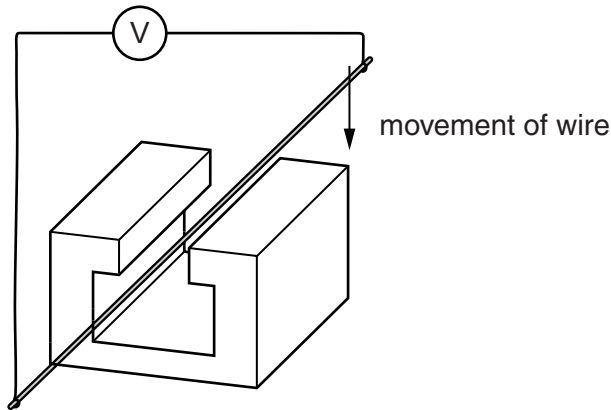

Fig. 14.1

(a) Describe what is observed on the voltmeter as the wire moves and then stops between the poles.

.....

 [2]

(b) State one factor affecting the magnitude of the induced e.m.f.

.....
 [1]

(c) The resistance of the wire is $9\ \Omega$.

The induced e.m.f. is 0.3 mV .

Calculate the current in the wire. State the unit.

current = unit [3]

15 A food web is shown in Fig. 15.1.

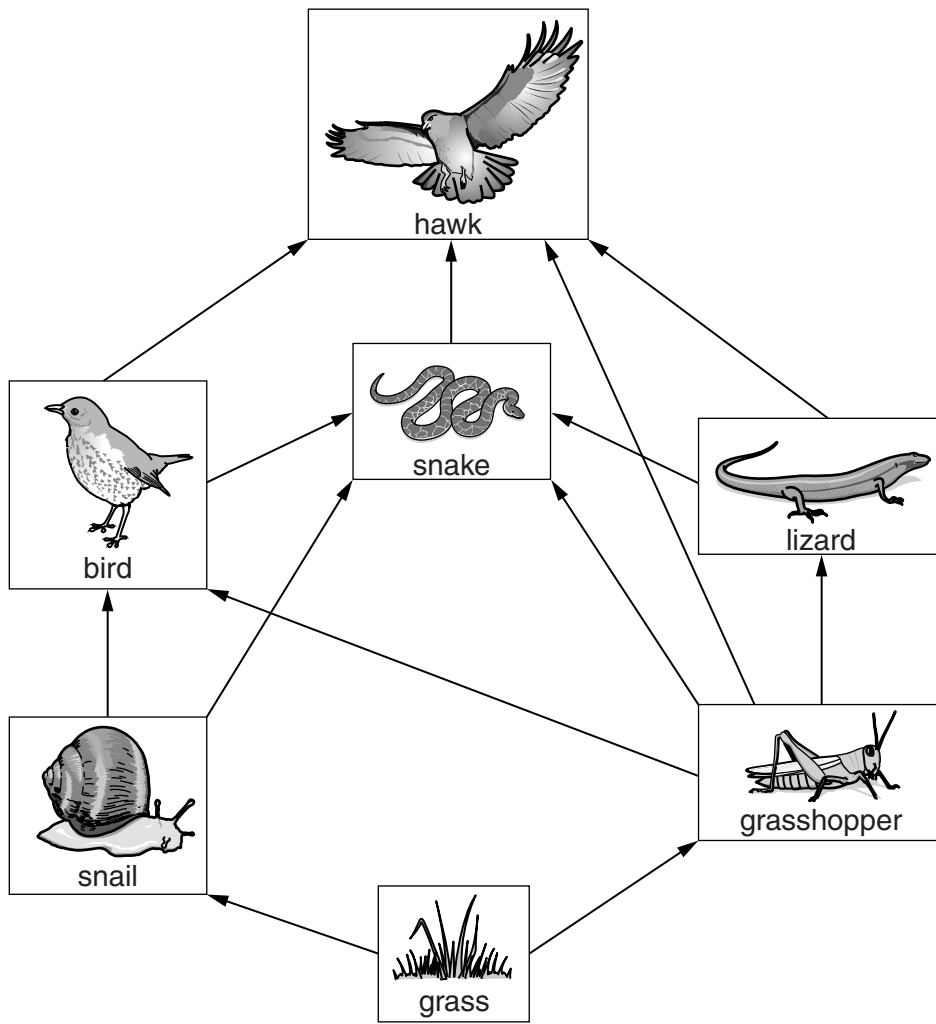

Fig. 15.1

(a) Name the type of energy used by the producers in this food web.

..... [1]

(b) Identify, from Fig. 15.1,

the name of the producer,

the number of herbivore species,

the number of carnivore species.

[3]

16 The reactions of four metallic elements **W**, **X**, **Y** and **Z** with hydrochloric acid and water are described below.

The letters are not the chemical symbols of the elements.

X reacts with dilute hydrochloric acid and steam.

Y reacts violently with cold water.

W does not react with hydrochloric acid.

Z reacts with hydrochloric acid but not with steam.

(a) Deduce the order of reactivity of the metals.

Use the letters to complete Table 16.1.

Table 16.1

	most reactive \longrightarrow least reactive			
metal				

[2]

(b) The oxide of **W** is reduced by heating in a stream of hydrogen gas.

(i) Explain the meaning of the word *reduced*.

.....
 [1]

(ii) In terms of reactivity, explain why the oxide of **W** is reduced by hydrogen.

.....
 [1]

(c) State one physical property that all metals have in common.

..... [1]

17 The wiring in a mains plug that is connected to an appliance is shown in Fig. 17.1.

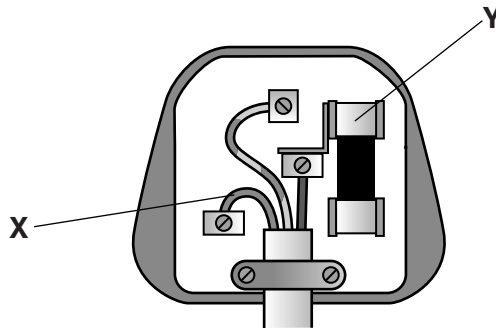

Fig 17.1

(a) (i) Name the wire labelled X.

..... [1]

(ii) Describe how component Y acts to prevent an excessive current in the appliance.

.....

 [2]

(b) A mains plug attached to an appliance with double insulation does not need an earth wire.

Explain what is meant by *double insulation*.

.....
 [1]

(c) A student is asked to wire a plug for an appliance that uses 5 A.

He is given the following fuses to choose to use in the plug:

1 A 3 A 5 A 7 A 13 A

State which fuse he should use and explain your choice.

fuse

explanation

..... [2]

18 The female reproductive system is shown in Fig. 18.1.

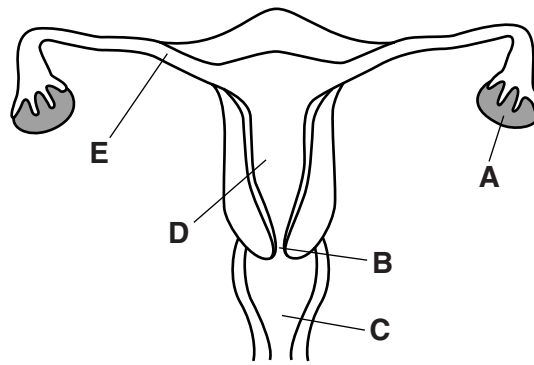

Fig. 18.1

State the letter of the part where

a zygote may be formed,

fertilisation takes place,

the fetus develops.

[3]

19 Selenium is in Group VI of the Periodic Table.

Selenium reacts with hydrogen to form hydrogen selenide, H_2Se .

(a) Complete Fig. 19.1 to show the arrangement of the outer-shell electrons in a molecule of hydrogen selenide.

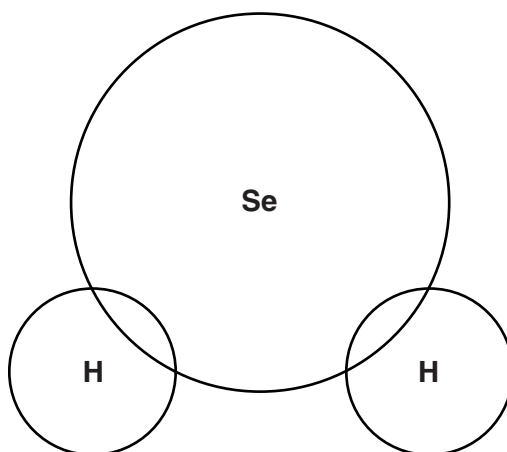

Fig. 19.1

[2]

(b) Hydrogen selenide dissolves in water producing an acidic solution.

(i) State the name of the ion which causes this solution to be acidic.

..... [1]

(ii) When this solution is tested with Universal Indicator, it changes to an orange colour.

Suggest the pH value of this solution. [1]

20 A container designed to store radioactive sources is shown in Fig. 20.1.

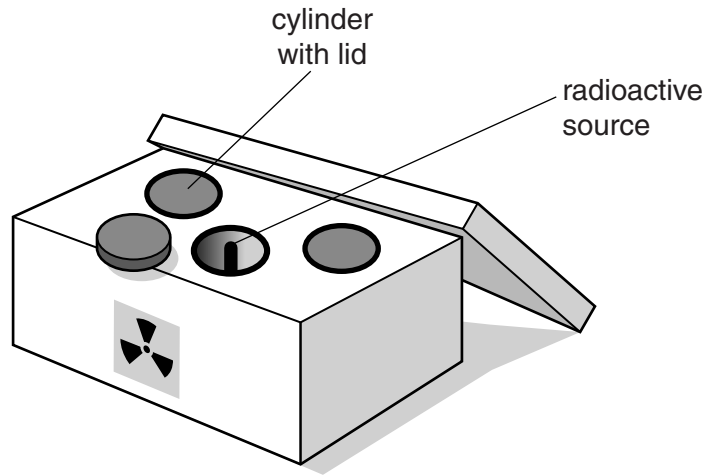

Fig. 20.1

In the container are three hollow cylinders, each of which can be covered with a lid.

When they are not in use, each radioactive source is placed inside a cylinder.

- (a) Suggest a suitable material for making cylinders and their lids for the storage of a gamma ray source and explain why this material is suitable.

material

explanation

.....

..... [2]

- (b) The activity of one of the sources stored in the box is measured once each year for twenty years.

The results are shown on the graph in Fig. 20.2

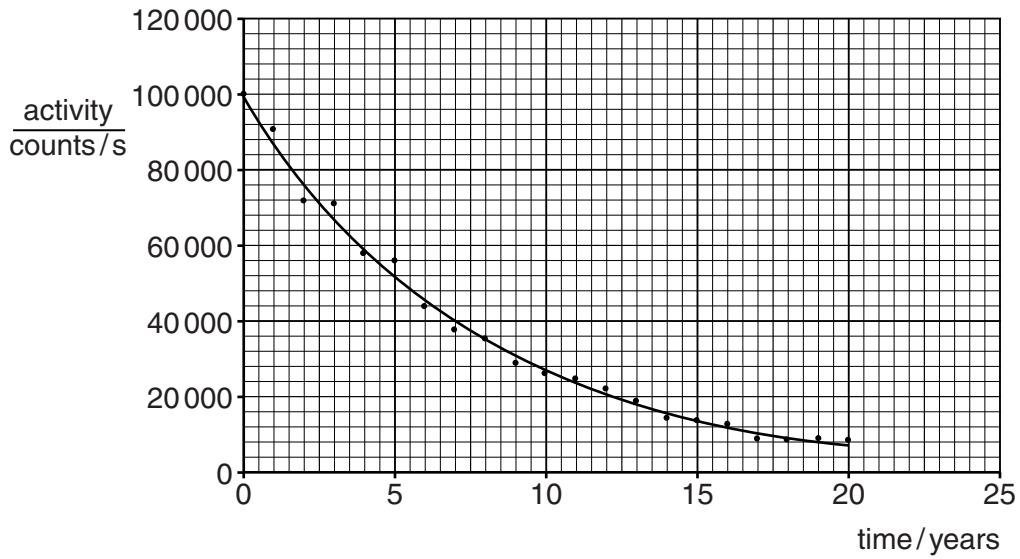

Fig. 20.2

Use Fig. 20.2 to

- (i) determine the activity of the source at time 12 years,

activity = counts/second [1]

- (ii) calculate the half-life of the source.

half-life = years [1]

BLANK PAGE

Permission to reproduce items where third-party owned material protected by copyright is included has been sought and cleared where possible. Every reasonable effort has been made by the publisher (UCLES) to trace copyright holders, but if any items requiring clearance have unwittingly been included, the publisher will be pleased to make amends at the earliest possible opportunity.

To avoid the issue of disclosure of answer-related information to candidates, all copyright acknowledgements are reproduced online in the Cambridge International Examinations Copyright Acknowledgements Booklet. This is produced for each series of examinations and is freely available to download at www.cie.org.uk after the live examination series.

Cambridge International Examinations is part of the Cambridge Assessment Group. Cambridge Assessment is the brand name of University of Cambridge Local Examinations Syndicate (UCLES), which is itself a department of the University of Cambridge.

The Periodic Table of Elements

		Group															
I	II	III	IV	V	VI	VII	VIII										
3 Li lithium 7	4 Be beryllium 9	5 B boron 11	6 C carbon 12	7 N nitrogen 14	8 O oxygen 16	9 F fluorine 19	10 Ne neon 20										
11 Na sodium 23	12 Mg magnesium 24	13 Al aluminium 27	14 Si silicon 28	15 P phosphorus 31	16 S sulfur 32	17 Cl chlorine 35.5	18 Ar argon 40										
19 K potassium 39	20 Ca calcium 40	21 Sc scandium 45	22 Ti titanium 48	23 V vanadium 51	24 Cr chromium 52	25 Mn manganese 55	26 Fe iron 56	27 Co cobalt 59	28 Ni nickel 59	29 Cu copper 64	30 Zn zinc 65	31 Ga gallium 70	32 Ge germanium 73	33 As arsenic 75	34 Se selenium 79	35 Br bromine 80	36 Kr krypton 84
37 Rb rubidium 85	38 Sr strontium 88	39 Y yttrium 89	40 Zr zirconium 91	41 Nb niobium 93	42 Mo molybdenum 96	43 Tc technetium —	44 Ru ruthenium 101	45 Rh rhodium 103	46 Pd palladium 106	47 Ag silver 108	48 Cd cadmium 112	49 In indium 115	50 Sn tin 119	51 Sb antimony 122	52 Te tellurium 128	53 I iodine 127	54 Xe xenon 131
55 Cs caesium 133	56 Ba barium 137	57–71 lanthanoids	72 Hf hafnium 178	73 Ta tantalum 181	74 W tungsten 184	75 Re rhenium 186	76 Os osmium 190	77 Ir iridium 192	78 Pt platinum 195	79 Au gold 197	80 Hg mercury 201	81 Tl thallium 204	82 Pb lead 207	83 Bi bismuth 209	84 Po polonium —	85 At astatine —	86 Rn radon —
87 Fr francium —	88 Ra radium —	89–103 actinoids	104 Rf rutherfordium —	105 Db dubnium —	106 Sg seaborgium —	107 Bh bohrium —	108 Hs hassium —	109 Mt meitnerium —	110 Ds darmstadtium —	111 Rg roentgenium —	112 Cn copernicium —	113 Nh nihonium —	114 Fl flerovium —	115 Mc moscovium —	116 Lv livermorium —	117 Ts tennessine —	118 Og oganeson —

Group

1
H
hydrogen
1

Key

atomic number

atomic symbol

name

relative atomic mass

57 La lanthanum 139	58 Ce cerium 140	59 Pr praseodymium 141	60 Nd neodymium 144	61 Pm promethium —	62 Sm samarium 150	63 Eu europium 152	64 Gd gadolinium 157	65 Tb terbium 159	66 Dy dysprosium 163	67 Ho holmium 165	68 Er erbium 167	69 Tm thulium 169	70 Yb ytterbium 173	71 Lu lutetium 175
89 Ac actinium —	90 Th thorium 232	91 Pa protactinium 231	92 U uranium 238	93 Np neptunium —	94 Pu plutonium —	95 Am americium —	96 Cm curium —	97 Bk berkelium —	98 Cf californium —	99 Es einsteinium —	100 Fm fermium —	101 Md mendelevium —	102 No nobelium —	103 Lr lawrencium —

lanthanoids

actinoids

The volume of one mole of any gas is 24 dm³ at room temperature and pressure (r.t.p.)